

UNION TOOL

Tungsten Carbide End Mills UNIMAX Series

NEW
Launched September 2023

UTWCOAT 2 Flutes Long Neck Ball End Mills

Total 73 Models

CWLB

Best performance in materials up to 40HRC

Suitable for a wide range of materials

Cost-efficient

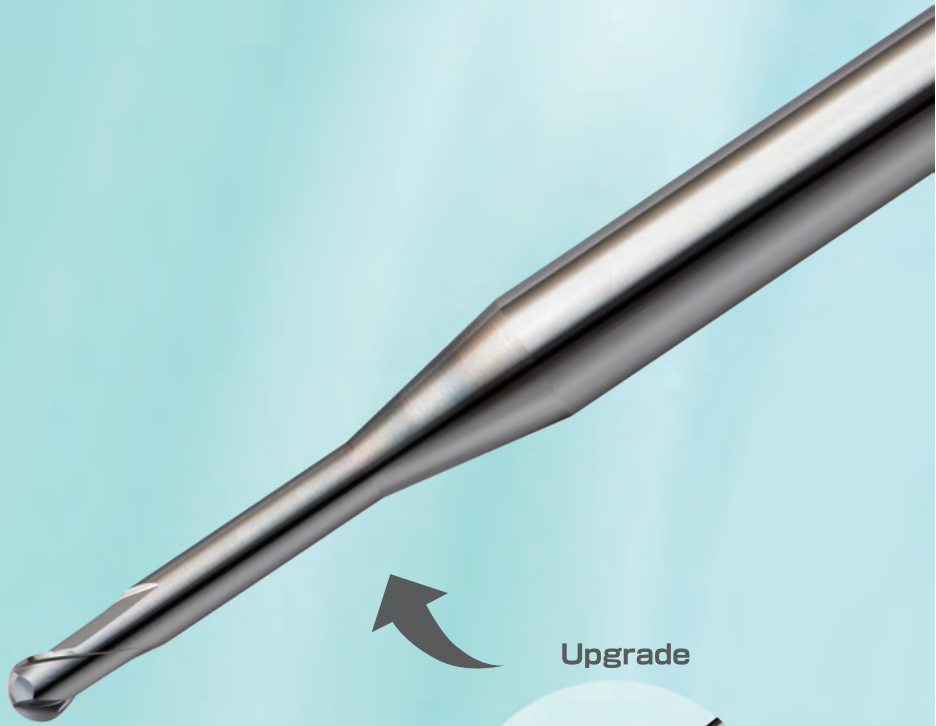

Upgrade



CSELB



UNION TOOL CO.

New coating UTWCOAT

New coating with the best performance achievable in work materials up to 40HRC.

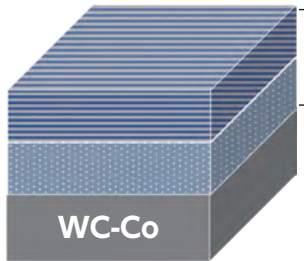

- High hardness and high toughness
- New nanocomposite structure offers ultra multilayer structure
- High toughness and wear resistance provide excellent performance in work materials up to 40HRC

Longer tool life and improved mirror surface finish

Longer tool life and improved mirror surface finish on SCM Prehardened Steels compared to conventional tools.

Longer tool life

Improved mirror surface finish

UTWCOAT
New Coating



Tool tip has a micro flatland design reducing milling surface roughness.



High Precision

Even higher accuracy than before !

Conventional CSELB

Radius of Ball Nose	Ball Radius Accuracy	Diameter Tolerance	Shank Diameter Tolerance
R0.5 ~ R1	± 0.005	0/-0.015	0/-0.005
R1.5 ~ R2			
R2.5 ~ R3			



CWLB

Unit (mm)

Radius of Ball Nose	Ball Radius Accuracy	Diameter Tolerance	Shank Diameter Tolerance
R0.5 ~ R1	± 0.003	0/-0.006	h4
R1.5 ~ R2	± 0.004	0/-0.009	
R2.5 ~ R3	± 0.005		

PXA30 (30 HRC) Roughing

Longer tool life.

Roughing - Tool wear comparison R0.5 × EL6

PXA30 (30 HRC)

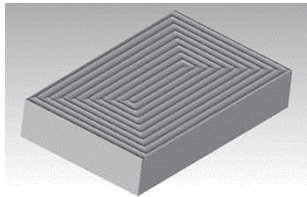

Work Size:
35 × 30 × 1.3 mm

Coolant:
Water Soluble

Tool after 65 min of milling

Spindle Speed	20,000 min ⁻¹
Feed Rate	1,500 mm/min
ap Axial Depth	0.1 mm
ae Radial Depth	0.2 mm
Cycle Time	65 min



Less wear compared to conventional and competitor's tools due to improved coating performance.

Roughing - Tool wear comparison R3 × EL30

PXA30 (30 HRC)

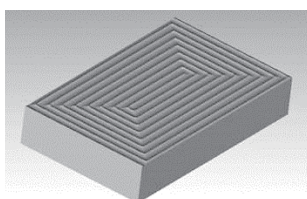

Work Size:
200 × 100 × 15 mm

Coolant:
Water Soluble

Tool after 190 min of milling

Spindle Speed	9,000 min ⁻¹
Feed Rate	2,700 mm/min
ap Axial Depth	0.4 mm
ae Radial Depth	1.9 mm
Cycle Time	190 min

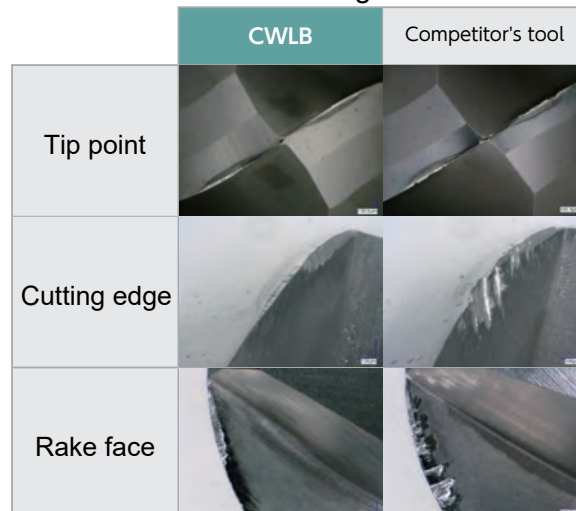

Excellent wear resistance compared to the competitor's tool for R3 roughing.

PXA30 (30 HRC) Finishing

Longer tool life and improved mirror surface finish.

Flat surface milling - Tool wear and milling surface comparison R0.5 × EL6

PXA30 (30 HRC)

Spindle Speed	20,000 min ⁻¹
Feed Rate	500 mm/min
a _p Axial Depth	0.03 mm
a _e Radial Depth	0.03 mm
Cycle Time	120 min

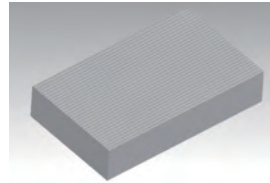

Work Size
15 × 10 × 0.06 mm

Coolant:
Water Soluble

Milling time and transition of Ra (Unit μm)

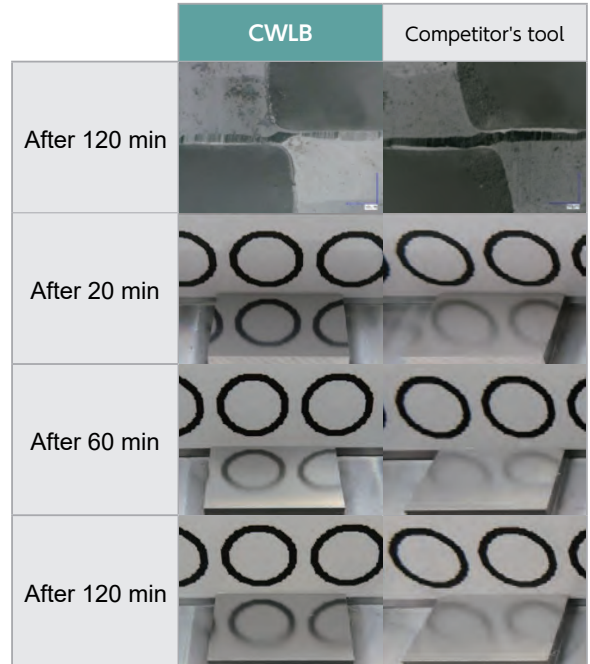
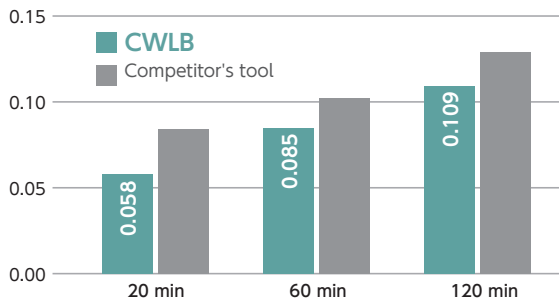

Normal wear on both CWLB and the competitor's tools, and still functional after 120 minutes of milling. Meanwhile CWLB offers better milling surface.

Curved surface milling - Tool wear and milling surface comparison R0.5 × EL6

PXA30 (30 HRC)

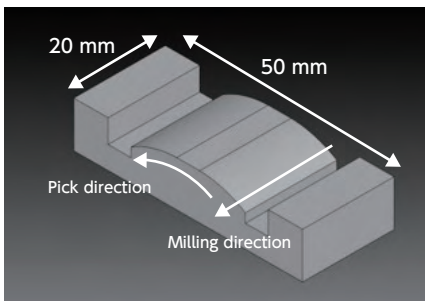

Coolant:
Water Soluble

Spindle Speed	20,000 min ⁻¹
Feed Rate	500 mm/min
a _p Axial Depth	0.03 mm
a _e Radial Depth	0.03 mm
Cycle Time	120 min

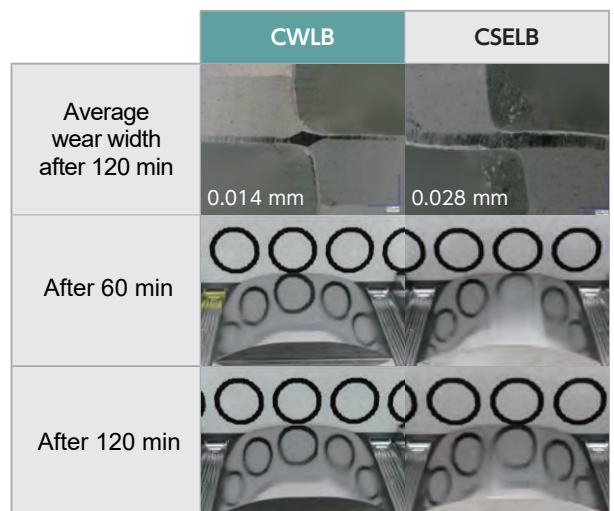

CWLB offers better milling surface on both flat and curved surfaces.

NAK80 (40HRC) Finishing

Longer tool life and improved mirror surface finish.

Finishing - Tool wear and milling surface comparison
R0.5 × EL6

NAK80 (40 HRC)

Spindle Speed	20,000 min ⁻¹
Feed Rate	500 mm/min
a _p Axial Depth	0.02 mm
a _e Radial Depth	0.02 mm
Cycle Time	135 min



Work Size
18 × 12 × 5 mm

Coolant:
Water Soluble

Milling time and transition of Ra (Unit μm)

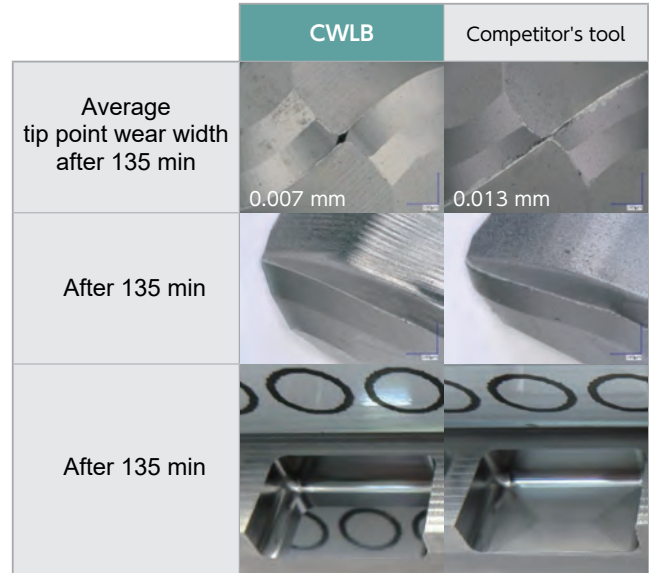
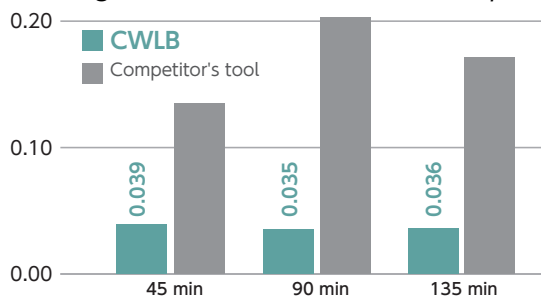

※Pocket wall removed for better visibility

CWLB offers better milling surface and wear resistance even on NAK80.

Carbon Steels S50C Roughing

Longer tool life.

Roughing - Tool damage comparison
R1.5 × EL12

Carbon Steels S50C

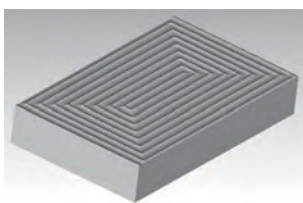

Work Size
200 × 105 × 1.12 mm

Coolant:
Water Soluble
(Through Spindle)

Spindle Speed	22,000 min ⁻¹
Feed Rate	2,300 mm/min
a _p Axial Depth	0.28 mm
a _e Radial Depth	0.7 mm
Cycle Time	60 min

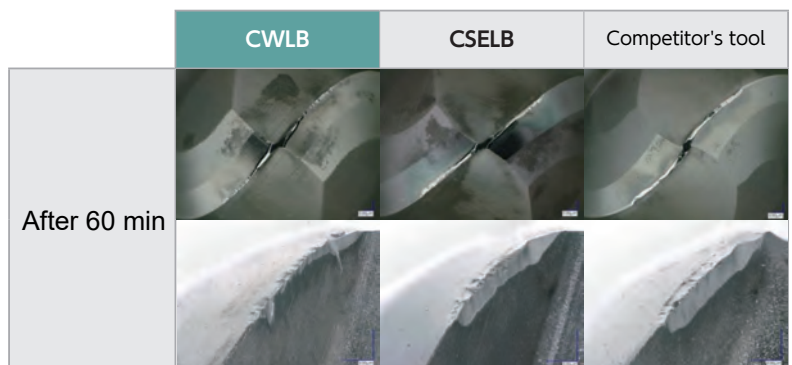

CWLB offers excellent wear resistance even on Carbon Steels.

Carbon Steels S50C Finishing

Longer tool life.

Finishing - Tool wear and surface roughness comparison
R0.5 × EL6

Carbon Steels S50C

Spindle Speed	20,000 min ⁻¹
Feed Rate	500 mm/min
a _p Axial Depth	0.02 mm
a _e Radial Depth	0.02 mm
Cycle Time	135 min



Work Size
18 × 12 × 5 mm

Coolant:
Water Soluble

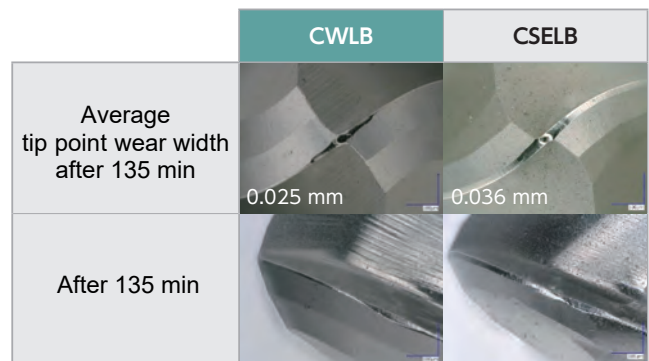
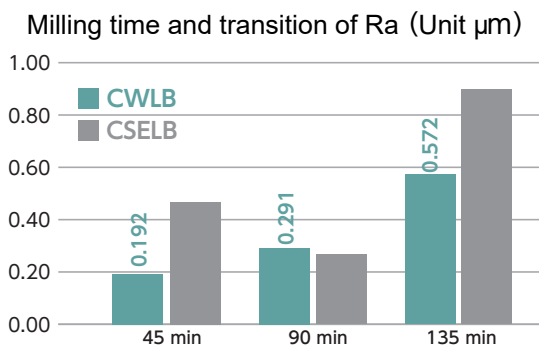

CWLB offers excellent wear resistance on Carbon Steels finishing.

Copper C1100 Finishing

Longer tool life and improved mirror surface finish.

Finishing - Tool wear and milling surface comparison
R0.5 × EL6

Copper C1100

Spindle Speed	20,000 min ⁻¹
Feed Rate	500 mm/min
a _p Axial Depth	0.02 mm
a _e Radial Depth	0.02 mm
Cycle Time	135 min



Work Size
18 × 12 × 5 mm

Coolant:
Oil Mist

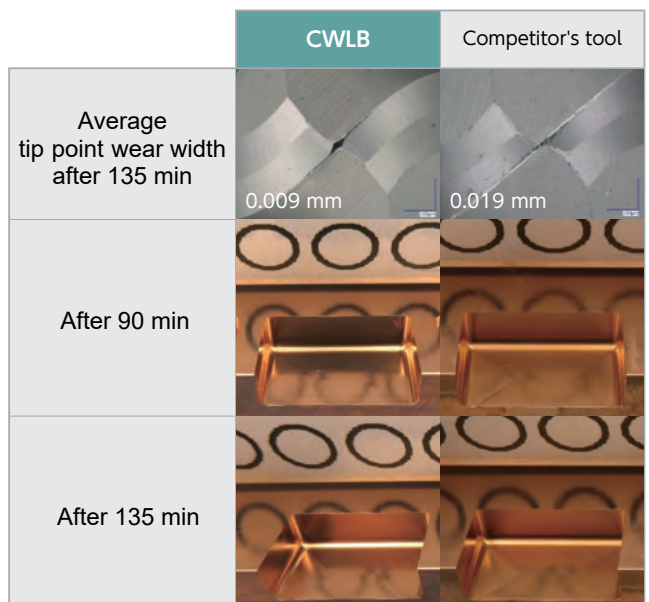

CWLB offers excellent wear resistance and milling surface.

※Pocket wall removed for better visibility

CWLB NEW



UTWCOAT 2 Flutes Long Neck Ball End Mills

R0.5~R3



★●○ Material Applications (★ Highly Recommended ● Recommended ○ Suggested)

Work Material																	
CARBON STEELS S45C S55C	ALLOY STEELS SK / SCM SUS	PREHARDENED STEELS NAK HPM	HARDENED STEELS					CAST IRON	ALUMINUM ALLOYS	GRAPHITE	COPPER	PLASTICS	GLASS FILLED PLASTICS	TITANIUM ALLOYS	HEAT RESISTANT ALLOYS	CEMENTED CARBIDE	HARD BRITTLE (NON-METALLIC) MATERIALS
			~ 50 HRC	~ 55 HRC	~ 60 HRC	~ 65 HRC	~ 70 HRC										
★	★	★	●					○	●		●			○	○		

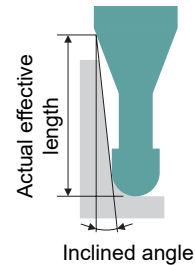
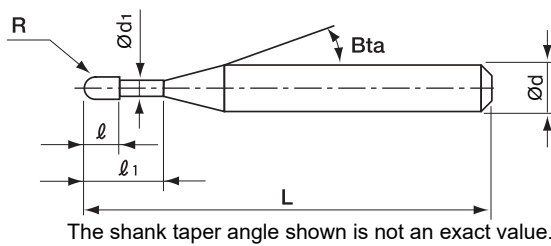

• High Accuracy

Even higher accuracy than our conventional tools !

Conventional CSELB

Radius of Ball Nose	Ball Radius Accuracy	Diameter Tolerance	Shank Diameter Tolerance
R0.5 ~ R1	± 0.005	0/-0.015	0/-0.005
R1.5 ~ R2			
R2.5 ~ R3			



CWLB

Unit (mm)

Radius of Ball Nose	Ball Radius Accuracy	Diameter Tolerance	Shank Diameter Tolerance
R0.5 ~ R1	± 0.003	0/-0.006	h4
R1.5 ~ R2	± 0.004	0/-0.009	
R2.5 ~ R3	± 0.005		

• Upgrade

Wear resistance and tool accuracy have been improved with HWLB and CWLB series.

CSELB			HSLB				HGLB	
Copper	Raw Materials	~ 30 HRC	~ 40 HRC	~ 50 HRC	~ 55 HRC	~ 60 HRC	~ 65 HRC	~ 70 HRC



CWLB			HWLB				HGLB	
Copper	Raw Materials	~ 30 HRC	~ 40 HRC	~ 50 HRC	~ 55 HRC	~ 60 HRC	~ 65 HRC	~ 70 HRC

Total 73 models

Unit (mm)

Model Number	Radius of Ball Nose R	Effective Length ℓ_1	Length of Cut ℓ	Neck Diameter ϕd_1	Shank Taper Angle Bta	Overall Length L	Shank Diameter ϕd	Suggested Retail Price ¥	Effective Length by Inclined Angles				
									30°	1°	1°30'	2°	3°
CWLB 2010-020	R0.5	2	0.8	0.98	11°	45	4	2,820	2.18	2.27	2.37	2.47	2.72
CWLB 2010-025		2.5				45	4	2,820	2.71	2.82	2.94	3.08	3.41
CWLB 2010-030		3				45	4	2,820	3.23	3.37	3.52	3.69	4.09
CWLB 2010-030-6		3				50	6	4,470	3.23	3.37	3.52	3.69	4.09
CWLB 2010-040		4				45	4	3,190	4.28	4.47	4.68	4.91	5.46
CWLB 2010-040-6		4				50	6	4,930	4.28	4.47	4.68	4.91	5.46
CWLB 2010-050		5				45	4	3,190	5.32	5.57	5.83	6.13	6.83
CWLB 2010-060		6				45	4	3,460	6.37	6.66	6.99	7.35	8.20
CWLB 2010-060-6		6				50	6	5,200	6.37	6.66	6.99	7.35	8.20
CWLB 2010-070		7				45	4	3,460	7.42	7.76	8.14	8.57	9.57
CWLB 2010-080		8				45	4	3,460	8.47	8.86	9.30	9.79	10.94
CWLB 2010-090		9				45	4	3,460	9.51	9.96	10.46	11.00	12.31
CWLB 2010-100		10				45	4	3,460	10.56	11.06	11.61	12.22	13.68
CWLB 2010-100-6		10				50	6	5,200	10.56	11.06	11.61	12.22	13.68
CWLB 2010-120		12				45	4	3,460	12.65	13.26	13.92	14.66	16.42
CWLB 2010-120-6		12				50	6	5,200	12.65	13.26	13.92	14.66	16.42
CWLB 2010-140		14				50	4	4,020	14.75	15.45	16.23	17.10	19.15
CWLB 2010-160		16				50	4	4,740	16.84	17.65	18.55	19.54	21.89
CWLB 2010-200		20				55	4	5,740	21.03	22.05	23.17	24.41	27.37
CWLB 2015-030		R0.75				3	1.2	1.47	11°	45	4	3,280	3.17
CWLB 2015-040	4		45	4	3,280	4.22				4.39	4.59	4.80	5.31
CWLB 2015-060	6		45	4	3,280	6.31				6.59	6.90	7.24	8.05
CWLB 2015-080	8		45	4	3,460	8.41				8.79	9.21	9.68	10.79
CWLB 2015-100	10		45	4	3,740	10.50				10.99	11.52	12.12	13.53
CWLB 2015-120	12		45	4	4,020	12.60				13.18	13.83	14.55	16.26
CWLB 2015-140	14		50	4	4,020	14.69				15.38	16.14	16.99	19.00
CWLB 2015-160	16		50	4	4,020	16.78				17.58	18.46	19.43	21.74
CWLB 2015-200	20		55	4	4,020	20.97				21.97	23.08	24.31	No Interference
CWLB 2016-040	R0.8		4	1.28	1.58	11°				45	4	4,560	4.19
CWLB 2016-080		8	45				4	4,650	8.38	8.76	9.17	9.64	10.74

Model Number	Radius of Ball Nose R	Effective Length ℓ_1	Length of Cut ℓ	Neck Diameter ϕd_1	Shank Taper Angle Bta	Overall Length L	Shank Diameter ϕd	Suggested Retail Price ¥	Effective Length by Inclined Angles				
									30°	1°	1°30'	2°	3°
CWLB 2020-030	R1	3	1.6	1.98	11°	45	4	2,820	3.13	3.24	3.36	3.49	3.81
CWLB 2020-040		4				45	4	2,820	4.18	4.34	4.52	4.71	5.18
CWLB 2020-060		6				45	4	3,190	6.27	6.54	6.83	7.15	7.92
CWLB 2020-060-6		6				50	6	4,830	6.27	6.54	6.83	7.15	7.92
CWLB 2020-080		8				45	4	3,460	8.37	8.73	9.14	9.59	10.66
CWLB 2020-080-6		8				50	6	5,200	8.37	8.73	9.14	9.59	10.66
CWLB 2020-100		10				45	4	3,460	10.46	10.93	11.45	12.03	13.40
CWLB 2020-100-6		10				50	6	5,200	10.46	10.93	11.45	12.03	13.40
CWLB 2020-120		12				45	4	3,460	12.55	13.13	13.76	14.47	16.14
CWLB 2020-120-6		12				50	6	5,200	12.55	13.13	13.76	14.47	16.14
CWLB 2020-140		14				50	4	3,460	14.65	15.32	16.07	16.90	18.87
CWLB 2020-160		16				50	4	3,460	16.74	17.52	18.38	19.34	No Interference
CWLB 2020-160-6		16				60	6	5,200	16.74	17.52	18.38	19.34	21.61
CWLB 2020-200		20				55	4	3,460	20.93	21.92	23.01	24.22	No Interference
CWLB 2020-200-6		20				70	6	5,200	20.93	21.92	23.01	24.22	27.09
CWLB 2020-250		25				65	4	4,830	26.17	27.41	28.79	No Interference	No Interference
CWLB 2020-300	30	70	4	5,470	31.40	32.90	34.56	No Interference	No Interference				
CWLB 2030-060-3	R1.5	6	2.4	2.95	-	60	3	3,190	No Interference	No Interference	No Interference	No Interference	No Interference
CWLB 2030-060-4		6			60	4	3,190	6.32	6.56	6.83	7.13	7.84	
CWLB 2030-060		6			60	6	3,460	6.32	6.56	6.83	7.13	7.84	
CWLB 2030-080		8			60	6	3,460	8.42	8.76	9.14	9.57	10.58	
CWLB 2030-100		10			60	6	4,020	10.51	10.96	11.45	12.00	13.31	
CWLB 2030-120		12			60	6	4,190	12.60	13.16	13.77	14.44	16.05	
CWLB 2030-140		14			60	6	4,650	14.70	15.35	16.08	16.88	18.79	
CWLB 2030-160		16			60	6	4,650	16.79	17.55	18.39	19.32	21.53	
CWLB 2030-200		20			70	6	4,470	20.98	21.94	23.01	24.19	27.01	
CWLB 2030-250		25			70	6	4,470	26.21	27.44	28.79	30.29	No Interference	
CWLB 2030-300		30			70	6	5,100	31.45	32.93	34.57	36.38	No Interference	

Model Number	Radius of Ball Nose R	Effective Length ℓ_1	Length of Cut ℓ	Neck Diameter ϕd_1	Shank Taper Angle Bta	Overall Length L	Shank Diameter ϕd	Suggested Retail Price ¥	Effective Length by Inclined Angles				
									30°	1°	1° 30'	2°	3°
CWLB 2040-080-4	R2	8	3.2	3.95	-	70	4	3,340	No Interference	No Interference	No Interference	No Interference	No Interference
CWLB 2040-080		8			70	6	3,560	8.39	8.71	9.06	9.46	10.39	
CWLB 2040-100		10			70	6	3,560	10.48	10.91	11.37	11.89	13.13	
CWLB 2040-120		12			70	6	4,650	12.58	13.10	13.69	14.33	15.87	
CWLB 2040-160		16			70	6	4,650	16.77	17.50	18.31	19.21	No Interference	
CWLB 2040-200		20			70	6	4,650	20.95	21.89	22.93	24.08	No Interference	
CWLB 2040-250		25			70	6	4,650	26.19	27.39	28.71	30.18	No Interference	
CWLB 2040-300		30			70	6	4,650	31.42	32.88	34.49	No Interference	No Interference	
CWLB 2040-400		40			90	6	6,020	41.89	43.87	No Interference	No Interference	No Interference	
CWLB 2060-100		R3			10	4.8	5.95	-	80	6	5,840	No Interference	No Interference
CWLB 2060-150	15		80	6	5,840				No Interference	No Interference	No Interference	No Interference	No Interference
CWLB 2060-200	20		80	6	5,840				No Interference	No Interference	No Interference	No Interference	No Interference
CWLB 2060-250	25		80	6	5,840				No Interference	No Interference	No Interference	No Interference	No Interference
CWLB 2060-300	30		80	6	6,020				No Interference	No Interference	No Interference	No Interference	No Interference
CWLB 2060-350	35		80	6	6,200				No Interference	No Interference	No Interference	No Interference	No Interference

WORK MATERIAL			COPPER / ALUMINUM ALLOYS				CARBON STEELS / ALLOY STEELS S45C / S50C / SK / SCM (~325HB)				PREHARDENED STEELS NAK80 / STAVAX / HPM38 (30~45HRC)				STAVAX / HPM38 / SKD61 STAVAX / HPM38 / SKD61 (45~55HRC)			
Model Number	Radius of Ball Nose (mm)	Effective Length (mm)	Spindle Speed (min ⁻¹)	Feed Rate (mm/min)	a _p Axial Depth (mm)	a _e Radial Depth (mm)	Spindle Speed (min ⁻¹)	Feed Rate (mm/min)	a _p Axial Depth (mm)	a _e Radial Depth (mm)	Spindle Speed (min ⁻¹)	Feed Rate (mm/min)	a _p Axial Depth (mm)	a _e Radial Depth (mm)	Spindle Speed (min ⁻¹)	Feed Rate (mm/min)	a _p Axial Depth (mm)	a _e Radial Depth (mm)
2010-020	R0.5	2	30,000	2,000	0.12	0.36	30,000	1,600	0.08	0.16	30,000	1,600	0.09	0.18	22,000	1,600	0.09	0.13
2010-025		2.5	30,000	2,000	0.12	0.36	30,000	1,600	0.08	0.16	30,000	1,600	0.09	0.18	22,000	1,600	0.09	0.13
2010-030		3	30,000	1,800	0.11	0.33	24,000	1,600	0.07	0.14	30,000	1,500	0.08	0.16	21,500	1,400	0.08	0.12
2010-040		4	30,000	1,700	0.09	0.27	24,000	1,500	0.065	0.13	30,000	1,300	0.075	0.15	21,500	1,300	0.075	0.1
2010-050		5	30,000	1,600	0.08	0.24	24,000	1,400	0.06	0.12	30,000	1,200	0.07	0.14	21,500	1,200	0.06	0.09
2010-060		6	30,000	1,400	0.06	0.18	18,000	1,200	0.04	0.12	30,000	1,100	0.06	0.12	21,500	1,100	0.05	0.1
2010-070		7	27,000	1,200	0.05	0.15	17,000	1,000	0.03	0.09	24,000	800	0.04	0.12	20,000	900	0.03	0.09
2010-080		8	24,000	1,000	0.04	0.12	16,500	900	0.027	0.081	18,500	620	0.035	0.1	18,500	580	0.025	0.1
2010-090		9	22,000	720	0.035	0.11	15,500	700	0.02	0.08	16,500	550	0.025	0.1	16,500	500	0.02	0.08
2010-100		10	20,000	650	0.03	0.09	15,000	500	0.018	0.072	14,800	490	0.02	0.08	14,800	430	0.015	0.06
2010-120		12	18,000	600	0.02	0.08	15,000	500	0.016	0.064	13,400	380	0.01	0.05	13,400	380	0.008	0.04
2010-140		14	16,000	530	0.015	0.06	14,000	460	0.015	0.06	12,000	350	0.008	0.04	12,000	350	0.006	0.03
2010-160		16	14,000	460	0.014	0.056	14,000	460	0.014	0.056	10,500	250	0.005	0.025	10,500	250	0.005	0.025
2010-200		20	13,000	430	0.008	0.04	13,000	430	0.008	0.04	9,000	150	0.003	0.015	9,000	150	0.003	0.015
2015-030	R0.75	3	30,000	2,000	0.15	0.45	30,000	1,600	0.12	0.24	30,000	1,700	0.12	0.24	18,000	1,500	0.12	0.18
2015-040		4	30,000	1,800	0.14	0.42	30,000	1,500	0.11	0.22	30,000	1,600	0.11	0.22	18,000	1,400	0.11	0.17
2015-060		6	30,000	1,800	0.12	0.36	23,000	1,300	0.1	0.2	30,000	1,400	0.1	0.2	15,000	1,200	0.1	0.16
2015-080		8	30,000	1,600	0.11	0.33	18,000	1,100	0.08	0.16	30,000	1,200	0.08	0.2	14,000	1,000	0.08	0.16
2015-100		10	23,000	1,200	0.09	0.27	15,000	850	0.06	0.15	23,500	900	0.06	0.18	14,000	700	0.05	0.15
2015-120		12	16,000	900	0.07	0.21	13,000	600	0.05	0.15	13,000	650	0.05	0.15	13,000	550	0.03	0.12
2015-140		14	14,500	700	0.05	0.19	10,500	550	0.04	0.12	10,500	500	0.04	0.12	10,500	470	0.025	0.1
2015-160		16	13,000	650	0.04	0.16	10,000	550	0.03	0.12	8,850	400	0.03	0.12	8,850	390	0.02	0.08
2015-200	20	10,500	530	0.02	0.1	9,200	470	0.02	0.1	8,000	320	0.012	0.06	8,000	320	0.012	0.06	
2016-040	R0.8	4	30,000	2,000	0.16	0.48	30,000	1,600	0.12	0.24	30,000	1,800	0.12	0.36	18,000	1,400	0.1	0.2
2016-080		8	30,000	1,700	0.15	0.45	15,000	1,100	0.1	0.2	30,000	1,500	0.12	0.24	13,500	1,000	0.08	0.24
2020-030	R1	3	30,000	2,000	0.2	0.6	30,000	2,000	0.21	0.42	30,000	2,000	0.2	0.6	16,000	1,300	0.17	0.5
2020-040		4	30,000	2,000	0.2	0.6	30,000	2,000	0.21	0.42	30,000	2,000	0.2	0.6	16,000	1,300	0.17	0.5
2020-060		6	30,000	2,000	0.2	0.6	30,000	2,000	0.21	0.42	30,000	2,000	0.2	0.6	14,000	1,100	0.15	0.4
2020-080		8	30,000	2,000	0.2	0.6	30,000	2,000	0.18	0.36	30,000	2,000	0.16	0.56	12,000	950	0.12	0.4
2020-100		10	30,000	2,000	0.2	0.6	30,000	2,000	0.17	0.36	30,000	2,000	0.13	0.45	10,800	850	0.1	0.4
2020-120		12	30,000	2,000	0.18	0.54	30,000	2,000	0.12	0.36	30,000	2,000	0.1	0.35	10,800	850	0.08	0.32
2020-140		14	22,000	1,450	0.15	0.5	22,000	1,450	0.11	0.33	20,000	1,300	0.08	0.24	10,800	850	0.06	0.24
2020-160		16	15,000	1,000	0.1	0.4	15,000	1,000	0.07	0.28	10,800	700	0.06	0.18	10,800	600	0.03	0.15
2020-200		20	12,000	800	0.07	0.28	12,000	800	0.05	0.2	8,650	500	0.04	0.16	8,650	450	0.02	0.1
2020-250		25	9,000	600	0.04	0.2	9,000	600	0.035	0.17	7,800	440	0.025	0.1	7,800	440	0.016	0.08
2020-300	30	7,000	470	0.035	0.17	7,000	470	0.03	0.15	7,000	350	0.02	0.08	7,000	350	0.01	0.05	
2030-060	R1.5	6	24,000	2,500	0.32	0.9	24,000	2,500	0.32	0.9	24,000	2,500	0.3	0.9	14,000	1,400	0.25	0.76
2030-080		8	24,000	2,500	0.32	0.9	24,000	2,500	0.32	0.9	24,000	2,500	0.3	0.9	14,000	1,400	0.25	0.76
2030-100		10	22,000	2,300	0.28	0.8	22,000	2,300	0.28	0.8	24,000	2,500	0.25	0.75	13,000	1,200	0.25	0.76
2030-120		12	22,000	2,300	0.28	0.7	22,000	2,300	0.28	0.7	20,000	2,100	0.2	0.65	10,700	1,000	0.18	0.54
2030-140		14	20,000	2,100	0.24	0.6	20,000	2,100	0.24	0.6	18,000	1,850	0.18	0.5	9,400	800	0.16	0.48
2030-160		16	20,000	2,100	0.24	0.6	20,000	2,100	0.24	0.6	16,000	1,650	0.16	0.5	9,000	700	0.14	0.42
2030-200		20	14,000	1,800	0.2	0.45	14,000	1,800	0.2	0.45	11,000	1,000	0.12	0.36	7,000	600	0.1	0.3
2030-250		25	8,000	1,250	0.16	0.32	8,000	1,250	0.16	0.32	6,400	510	0.08	0.24	5,600	390	0.06	0.18
2030-300	30	6,000	1,000	0.1	0.3	6,000	1,000	0.1	0.3	4,600	450	0.05	0.2	3,900	370	0.04	0.12	

WORK MATERIAL			COPPER / ALUMINUM ALLOYS				CARBON STEELS / ALLOY STEELS S45C / S50C / SK / SCM (~325HB)				PREHARDENED STEELS NAK80 / STAVAX / HPM38 (30~45HRC)				STAVAX / HPM38 / SKD61 STAVAX / HPM38 / SKD61 (45~55HRC)			
Model Number	Radius of Ball Nose (mm)	Effective Length (mm)	Spindle Speed (min ⁻¹)	Feed Rate (mm/min)	a _p Axial Depth (mm)	a _e Radial Depth (mm)	Spindle Speed (min ⁻¹)	Feed Rate (mm/min)	a _p Axial Depth (mm)	a _e Radial Depth (mm)	Spindle Speed (min ⁻¹)	Feed Rate (mm/min)	a _p Axial Depth (mm)	a _e Radial Depth (mm)	Spindle Speed (min ⁻¹)	Feed Rate (mm/min)	a _p Axial Depth (mm)	a _e Radial Depth (mm)
2040-080	R2	8	24,000	2,900	0.4	1.2	24,000	2,900	0.4	1.2	18,000	2,400	0.4	1.2	11,000	2,000	0.34	1
2040-100		10	24,000	2,900	0.4	1.2	24,000	2,900	0.4	1.2	18,000	2,400	0.4	1.2	11,000	2,000	0.34	1
2040-120		12	24,000	2,900	0.4	1.2	24,000	2,900	0.4	1.2	18,000	2,400	0.4	1.2	9,700	1,500	0.28	0.85
2040-160		16	18,000	2,250	0.3	1	18,000	2,250	0.3	1	15,000	2,150	0.3	0.9	8,000	1,000	0.2	0.6
2040-200		20	15,000	1,900	0.3	0.9	15,000	1,900	0.3	0.9	12,000	1,750	0.2	0.7	7,000	750	0.15	0.45
2040-250		25	12,000	1,550	0.25	0.7	12,000	1,550	0.25	0.7	9,000	1,300	0.15	0.5	6,000	560	0.12	0.36
2040-300		30	7,000	1,400	0.2	0.5	7,000	1,400	0.2	0.5	7,000	850	0.1	0.3	5,000	460	0.08	0.2
2040-400		40	4,000	1,000	0.11	0.33	4,000	1,000	0.11	0.33	3,450	400	0.06	0.24	2,900	270	0.06	0.15
2060-100	R3	10	16,000	3,100	0.6	1.8	16,000	3,100	0.6	1.8	11,000	2,310	0.55	1.7	7,500	1,800	0.5	1.5
2060-150		15	16,000	3,100	0.6	1.8	16,000	3,100	0.6	1.8	11,000	2,310	0.55	1.7	7,500	1,800	0.5	1.5
2060-200		20	16,000	3,100	0.6	1.8	16,000	3,100	0.6	1.8	11,000	2,310	0.55	1.7	6,500	1,300	0.4	1.4
2060-250		25	13,000	2,600	0.45	1.5	13,000	2,600	0.45	1.5	10,000	1,800	0.4	1.3	5,300	840	0.32	0.9
2060-300		30	10,000	2,100	0.4	1.3	10,000	2,100	0.4	1.3	8,000	1,350	0.3	1.1	4,700	750	0.3	0.8
2060-350		35	8,000	1,800	0.38	1.1	8,000	1,800	0.38	1.1	7,000	1,100	0.26	0.9	4,200	670	0.25	0.6

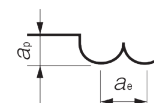

Note:

- Decrease the feed rate more than 50% from the milling parameters when slot milling.
- Decrease both spindle speed and feed rate proportionally when the milling parameters exceed the machine's maximum spindle speed, or when chattering and red-hot occur.
- Recommend oil coolant for Stainless Steels and Heat Resistant Alloys.
- Recommend wet coolant for Copper.



Advisory for Safe Use of End Mills

Correct application and operation is strongly advised to avoid clogging, abrasion, etc., that could cause serious accidents or injuries. Ignition or sparks generated during milling could lead to fire or extreme damage to the work piece. End Mills are made with very sharp cutting edges and must be handled with extra care.

- Never touch the cutting edge with your bare hands, as this could cause serious injury. Special caution is required when opening the package.
- Dropping the tool could cause breakage or flying debris, leading to serious injury.
- During milling, unexpected impact or shock on the tool could cause breakage or flying debris. Ensure to use protective items such as safety glasses and a face guard.
- For best results, fine parameter adjustment may be required, depending on the materials; milling shape and strategy; machine rigidity and spindle capability.
- Use a machine that has high rigidity and generates a low level of vibration. Recommend setting the runout control value at 5μm or below for the small diameter tools φ1 or below.
- Do not use flammable cutting oils.

Advisory for Regrinding End Mills

- Never regrind the tool without wearing safety glasses and a face guard.



<https://www.uniontool.co.jp>

0120-60-2620

Price & Specifications are subject to change without notice.

